

Standard Specifications

Item	Model Type	HC-49/US	HC-49US/SMD
Frequency		3.50~90.000MHZ	
Frequency Tolerance		±10ppm~±30ppm	
Frequency Characteristics		±30ppm or Specify	
Operating Temperature Range		-10°C~+60°C Standard, -40°C~+85°C Extended	
Storage Temperature Range		-40°C~+85°C	
Equivalent Series Resistance(ESR)		See Table	
Load Capacitance		20pf or Specify	
Shunt Capacitance		7.0pf Max	
Drive Level		100μW	
Aging (First year)		±5ppm/Year	

*Detail specifications refer to the individual specifications

Equivalent Series Resistance(ESR)

Frequency (MHZ)	Mode	ESR (Max Ω)
$3.5 \leq f < 4$	Fundamental	150
$4 \leq f < 6$	Fundamental	120
$6 \leq f < 10$	Fundamental	100
$10 \leq f < 30$	Fundamental	50
$30 \leq f < 35$	Fundamental	40
$35 \leq f < 70$	3rd overtone	80

Dimensions(unit:mm)

HC-49\US

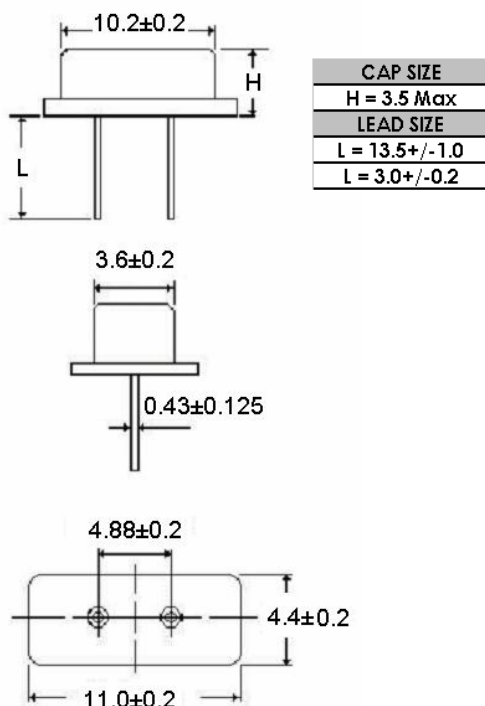

HC-49/US SMD

